



# FIBERSHIELD 4

## FIRE SHUTTERS

AS1530.4



-/240/-

EN12101.1



&lt;25m³/hour

The Fibershield 4 is ideal for medium to large openings up to 12m wide. The Fibershield 4 fire curtain offers a single compact head box and coil to truly maximise open plan designs.

The system provides fire resistance levels up to -/240/- when tested in accordance with AS1530.4:2014.

Fibershield 4 is made in Germany using a single overhead coil supported with patented floating bearings to create unmatched reliability over long to very long spans.

Backed by extensive durability testing – in excess of 10,000 cycles as a single coil (no overlaps), the Fibershield 4 system performance is well in excess of any overlapped multiple coil system.

- Fire tested in accordance with AS1530.4:2014
- Fire ratings up to -/240/-
- Approved for openings up to 12m wide
- Also complies with EN12101.1 Smoke Curtains





# FIBERSHIELD 4 Fire Curtain System

## INTRODUCTION



Fibershield 4 is a premium product, far outperforming any other. The system is also the largest 4 hour fire resistant system available and the only system tested and proven to resist high pressures experienced in buildings with mechanical smoke control or extraction systems.

## COMPLIANCE

Fibershield 4 fire curtains have been fire tested in accordance with AS1530.4 for a -/240/- fire rating and can be supplied and installed in accordance with AS1905.2 fire shutters.

The system complies with the requirements of EN12101.1 Smoke Curtains.

TARGET	PERFORMANCE DATA	RESULTS
FIRE PROTECTION	Fire Shutter	Complies with AS1905.2
	Fire Rating	-/240/- when fire tested in accordance with AS1530.4
	Radiant Heat	2.8kW/m <sup>2</sup> @ 3m and 30 minutes into the standard fire test
	Permeability	<25 m <sup>3</sup> /hour when tested in accordance with EN12101.1
SMOKE PROTECTION	Spread of Flame	0, 0, 0, 2 when tested in accordance with AS1530.3
	Group Number	Group 1 when tested in accordance with AS3837
	Cycle Test	10,000 open-close cycles
FUNCTIONALITY	Operating Speed	4.5 m/min (nominal)
	Maximum Pressure Differential	50Pa when fully closed for sizes < 100m <sup>2</sup>
	System Weight	35 kg/lineal metre of width
	Maximum Sizes	12,000mm max width x 4500mm max drop

### What you need to know

Zone Pressurisation can cause pressure differentials of up to 80Pa. It is not adequate to simply upgrade bottom bars to resist these pressures. Only Fibershield V has proven to function in these environments for over 10 years. Contact us to assist with your designs in buildings with zone pressurisation.

## I FUNCTION

### SYSTEM OPERATION

The system is typically in the open position to provide open plan during normal building use. On receipt of an alarm, the Fibershield 4 fire curtain gravity deploys (fail safe) to provide fire and smoke compartmentation. On reset of the Fire Indicator Panel, the system automatically rewinds back into the standby position.

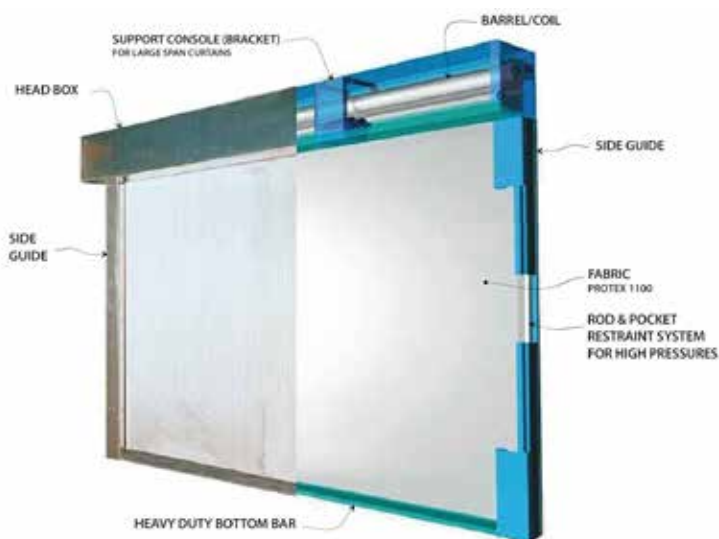

The control box is compact and does not require battery back up for compliant operation as this, combined with the motor provide power fail safe operation. Battery back up can be provided as an option for clients that wish to reduce the likelihood of nuisance deploys. The controller requires a standard 240V, 10A power supply and an alarm signal in the form of a normally closed dry contact. A localised smoke or heat detector may also be used to activate the system.

Please contact our technical department for details on 1300 665 471.

### EGRESS

When Fibershield 4 fire curtains are used as part of the egress strategy, rewind switches can be connected directly to the standard control box. The switches can be mounted on one or both sides of the wall. Once pressed the system will retract and then redeploy. The retraction is based on a timer. This timer can be set to open the curtain to a minimum height before redeployment.

### INSTALLATION

In line with Smoke Control's mission to provide customers with reliable solutions, the Fibershield V system is installed by our fully trained and approved installer network.

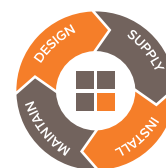

Fibershield 4 protecting an existing installation of non-fire rated glazing

### MAINTENANCE

As with all essential services Fibershield 4 should be maintained in strict accordance with our documented procedures by fully trained and competent technicians. Operational tests alone are not considered adequate and when conducted by inexperienced personnel, may lead to damage of the product. Smoke Control offers a comprehensive preventative maintenance program which has proven costs savings over the life of the product.

Please contact our maintenance department for details on 1300 665 471.



# FIBERSHIELD 4 Fire Curtain System

## APPLICATIONS

Built for distance, the Fibershield 4 long span vertical fire curtain is tough and reliable, and can be used to provide fire and smoke compartmentation in:

- theatres
- warehouses
- hospitals
- office buildings
- shopping centres

## ACCESSORIES

- self levelling bottom bar covers
- battery backup
- rewind switches
- curtain applied signage



Fibershield 4 (top) showing the open position with image below showing closed

## PRODUCT DIMENSIONS

Head box detail - Face Fixed

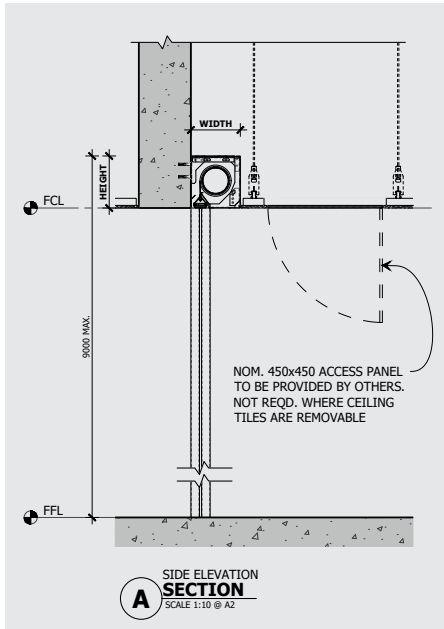

Side guide mounting options (Face Fixed, Left & Right)

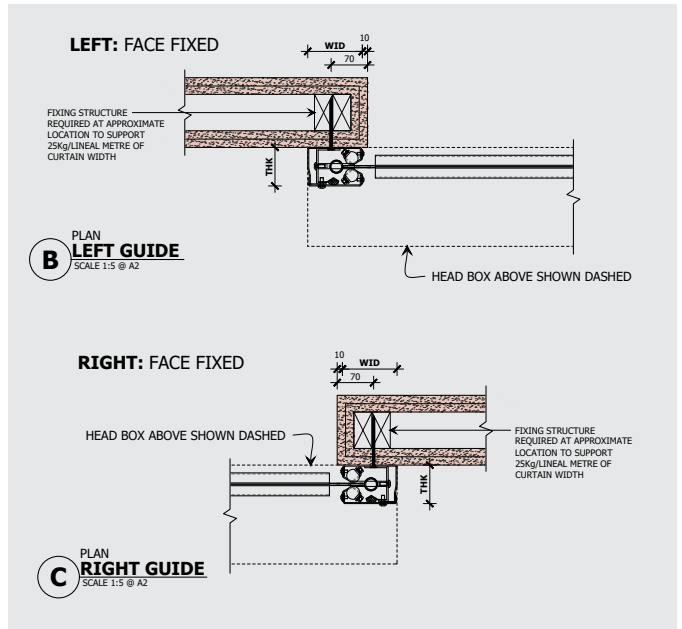



## GENERAL INFORMATION

### I TECHNICAL SUPPORT



Smoke Control offers obligation free technical support and pricing throughout your design and documentation stage so you can accurately prepare your budgets through value engineering.

You can also download the set of specifications, drawings and technical data from our website [www.smokecontrol.com.au](http://www.smokecontrol.com.au).

Contact our technical department to discuss your project requirements, or arrange a meeting.

Australia  
1300 665 471

International  
+61 2 96814000

New Zealand  
+64 9 300 1980

## A LITTLE MORE ABOUT US...

Smoke Control was established in 2003. We partner with leading local and international organisations to work with the new performance-based design environment - in addition to the traditional prescriptive environment - designing and installing systems to meet the challenging fire and smoke control demands of modern buildings.

Constant research and development continue to enhance our offering of fire windows, fire shutters and fire & smoke curtains, bringing the most innovative technology to both regular and unique project challenges. If you cannot find what you are looking for, please contact our team as we may already have a solution for you.

Smoke Control services all regions in Australia and New Zealand via our own offices and people. International customers can contact our Australian office by phone or email for your nearest distributor.

*We believe people deserve to work & live  
in safe & beautiful buildings*

